



Power Quotient International

— IC STORAGE SPECIALIST

DiskOnModule™ Series

Preliminary

FDXXX-XXXPS.XQ6(XXX)

4MB/8MB/16MB/32MB/64MB/128MB/256MB/384MB

Description

FDXXX-XXXPS.XQ6(XXX) series is PQI's **Secured DiskOnModule** based on Hyperstone NAND Type flash memory controller technology. This product complies with 40/44 PIN IDE (ATA) standard interface and is suitable for data storage memory medium for portable system. By using **Secured DiskOnModule** it is possible to operate good performance for the portable system, which have IDE interface slots.

Features

- Secure Function
- High Performance
- Non-volatile Flash Memory

The DOM is implemented by using NAND type flash memory, which is a high density, non-volatile read/write device. Flash data retention is guaranteed for at least 10 years, with no battery or other power source required.

- 100% True Mode IDE HDD Compatible
- Broad Operating System and Processors Supports
- Capacities 4~256Mbytes
- Low Power Consumption
- Robust Error Correction
- High Reliability

*Design with Hyperstone series product to access NAND type flash memory.

INTRODUCTION

1.About This Manual

This manual provides instructions for the installation and specification of PQI's **Secured DiskOnModule; Secured DiskOnModule** is designed for use in PCs, and their respective compatible computers.

2.What is **Secured DiskOnModule**?

PQI Secured DOM is the advanced storage device with unique security algorithm. Our Secured DOM can be worked in most computer operation systems such as Windows, DOS, and Linux... PQI Secured DOM provides the strongest protection for the treasure data. PQI Secured DOM offers the multi-layers password system to prohibit any illegal access. PQI provides the customers the library to set up the unique password system. Even PQI cannot know the password of the Secured DOM. The customer will be the only one who can hold all password of the Secured DOM.

PQI Secured DOM also can be partitioned by customer's demand. Secured DOM can be partitioned to 3 partitions: User zone, ROM zone, & Protect zone. The customer can decide the capacities of 3 partitions.

PQI also provide the whole design kits to help the customer to input the data into the Secured DOM. The customer can control the whole production process to prevent the data leak.

SPECIFICATION

Environment Specifications

Temperature	Operating	0°C to +70°C
	Non-Operating	-20°C to +85°C
Relative Humidity		8% to 95% (with no condensation)
Vibration	Operating	15G
	Non-operating	15G
Shock	Operating	1000G
	Non-operating	1000G

Configuration

Capacity	4Mbytes to 512Mbytes
Sector size	512Bytes

System Performance

Media transfer rate	write	2.0 MB/sec (typ.)
	read	3.3 MB/sec (typ.)
Interface burst transfer rate		
PIO mode 2		8.3 MB/sec (max)

Reliability

MTBF(@25°C)	300,000 hours
ECC	22bit per 256bytes

Power Requirement

Voltage	DC+3.3V±5%(Option)
	DC +5.0V±10%

Power Consumption

Read	21mA (typ.)
Write	28mA (typ.)
Sleep	0.3mA (typ.)

Physical specifications

Reference P29~P31

Capacity Specifications

Capacity	No. of Cylinders	No. of Sectors/Track	No. of Heads	Unformatted Capacity (Bytes)
8MB	495	16	2	8110080
16MB	995	16	2	16384000
32MB	500	16	8	32768000
64MB	500	32	8	65536000
128MB	500	32	16	131072000
256MB	1000	32	16	262144000
384MB	761	63	16	392749056

INSTALLTION GUIDE

BEFORE YOU BEGIN

To protect your DOM from static discharge by making sure you are well grounded before touching the DOM. We recommend wearing a grounded wrist strap throughout the installation process.

There are two kind of mode to setup Secured DiskOnModule.

1) Normally Mode ---- No Secure Function

STEP 1

1. Make sure your computer is turned off before you open the case.
2. Plug the DOM carefully into the IDE slot on your computer or host adapter.
Caution: Make sure to align pin1 on the computer or host adapter interface connector with pin 1 on your DOM. Pin 1 is indicated by a triangle on the DOM connector.
3. Connect the power cable of the DOM to an unused power connector of the computer.
Caution: If you need to remove your DOM, use **BOTH HANDS** to carefully pull out it.
4. Check all cable connections and then replace your computer cover.

STEP 2

Before you format or partition your new drive, you must configure your computer's BIOS so that the computer can recognize your new drive.

1. Turn your computer on. As your computer start up, watch the screen for a message describing how to run the system setup program (sometimes called BIOS or CMOS setup). This is usually done by pressing a special key, such as DELETE,ESC, or F1, during startup. See your computer manual for details. Press the appropriate key to run the system setup program.
2. If your BIOS provide automatic drive detection (an "AUTO" drive type), select this option. (We recommend that use Normal/CHS mode to partition your DOM to get the maximum formatted capacity.)

This allows your computer to configure itself automatically for your new drive.

If your BIOS doses not provide automatic drive detection, select "User-defined" drive setting and enter the CHS values from the table.

BIOS Settings (see specification)

Capacity	Cylinders	Heads	Sectors
(Unformatted)			

3. Save the settings and exit the System Setup program.
(Your computer will automatically reboot)

After you configure your computer, you can use the standard DOS commands to partition and format your DOM, as described below.

STEP 3

To partition your new DOM with Microsoft® DOS program:

1. Insert a bootable DOS diskette into your diskette drive and restart your computer.
2. Insert a DOS program diskette that contains the FDISK.EXE and FORMAT.COM programs into your diskette drive. Use the same DOS version that is on your bootable diskette. At the A: prompt, type FDISK and press ENTER.
3. If you have two IDE devices installed, the FDISK menu displays five options. Option five allows you to select the drive you want to partition. Make sure that your new drive is selected.
4. Select "Create DOS partition or logical DOS drive" by pressing 1. Then press ENTER.
5. Select "Create primary DOS partition" by pressing 1 again. Then press ENTER.

- Create your first drive partition. If you are creating a partition that will be used to boot your computer (drive C), make sure that the partition is marked active.
6. Create an extended partition and additional logical drives as necessary, until all the space on your new hard drive has been partitioned.
 7. When the partitioning is complete, FDISK reboots your computer.
Caution: Make sure to use the correct drive letters so that you do not format a drive that already contains data.
 8. At the A: prompt, type format c:/s, where c is the letter of your first new partition, Repeat the format process for all the new partitions you have created.
 9. After you format your drive, it is ready to use.

2) Secure Mode

There are two kind of protect function with Secured DiskOnModule. One is ROM Zone (Read Only) protect function, and the other one is Protect Zone protect function. Please refer the application note "Secured DiskOnModule with DOS/Linux".

Block Diagram

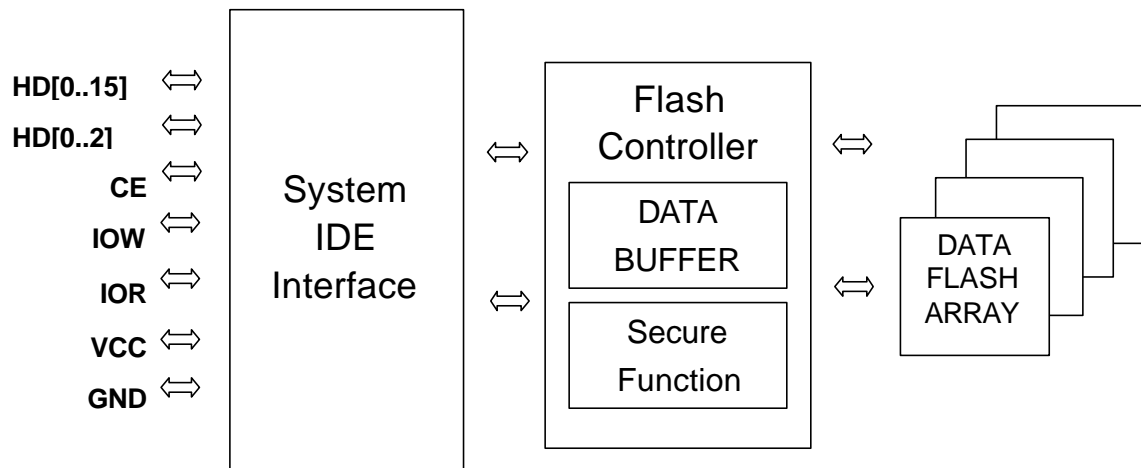

About Our Flash Management

In order to gain the best management for flash memory, PQI **Secured DiskOnModule** supports an efficient and swift algorithm. Due to the life of flash memory is limited, PQI try to increase the life of our flash product through the following arrangement. There are some blocks are reserved in flash memory and these blocks would not be used in normal operation. Once any block is fail, one of these reserved blocks will replace it and the data of the fail block would be transferred to the reserved block for keeping the data' s accuracy. After we used the above arrangement in flash memory, the life of the device will be longer than the device without it. When all of the reserved blocks have replaced the bad blocks, the device will be locked automatically to prevent programming, but the data can still be read out for back up.

Because the block of flash memory has a limited life, when the host writes data in the same address, PQI **Secured DiskOnModule** does not to program data into the same physical place of the flash memory in purpose, our algorithm will get the data precisely when the host wants to read the data.

ECC (Error Correction Code) feature also be built in our hardware and firmware, it will correct 1 bit errors, and detect 2 bits errors when they happened. ECC ensured the accuracy of the data, and decreased the effect of the cross talking on the bus.

Based on the latest hardware and firmware, PQI Secured DiskOnModule device can be up to 1.2MB/sec in writing data into medium, and be up to 2.5MB/sec in reading data from medium.

44/40 Pin Signal Assignment

The signals assigned for 44/40-pin applications are described in Table 1

Table 1 – Signal assignments for 44-pin ATA

Signal name	Connector contact	Conductor		Connector contact	Signal name
RESET-	1	1	2	2	Ground
DD7	3	3	4	4	DD8
DD6	5	5	6	6	DD9
DD5	7	7	8	8	DD10
DD4	9	9	10	10	DD11
DD3	11	11	12	12	DD12
DD2	13	13	14	14	DD13
DD1	15	15	16	16	DD14
DD0	17	17	18	18	DD15
Ground	19	19	20	20	(keypin)
DMARQ	21	21	22	22	Ground
DIOW-	23	23	24	24	Ground
DIOR-	25	25	26	26	Ground
IORDY	27	27	28	28	CSEL
DMACK-	29	29	30	30	Ground
INTRQ	31	31	32	32	reserved
DA1	33	33	34	34	PDIAG-
DA0	35	35	36	36	DA2
CS0-	37	37	38	38	CS1-
DASP-	39	39	40	40	Ground
+5 V (logic) (see note)	41	41	42	42	+5 V (Motor) (see note)
Ground(return) (see note)	43	43	44	44	TYPE- (0=ATA) (see note)
NOTE – Pins which are additional to those of the 40-pin cable.					

Interface Signal Assignments And Descriptions

Signal summary

The physical interface consists of receivers and drivers communicating through a set of conductors using an asynchronous interface protocol. Table 2 defines the signal names.

Table 2 - Interface signal name assignments

Description	Host	Dir	Dev	Acronym
Cable select	(see note)			CSEL
Chip select0		→		CS0-
Chip select1		→		CS1-
Data bus bit 0		↔		DD0
Data bus bit 1		↔		DD1
Data bus bit 2		↔		DD2
Data bus bit 3		↔		DD3
Data bus bit 4		↔		DD4
Data bus bit 5		↔		DD5
Data bus bit 6		↔		DD6
Data bus bit 7		↔		DD7
Data bus bit 8		↔		DD8
Data bus bit 9		↔		DD9
Data bus bit 10		↔		DD10
Data bus bit 11		↔		DD11
Data bus bit 12		↔		DD12
Data bus bit 13		↔		DD13
Data bus bit 14		↔		DD14
Data bus bit 15		↔		DD15
Device active or slave (Device 1) present	(see note)			DASP-
Device address bit 0		→		DA0
Device address bit 1		→		DA1
Device address bit 2		→		DA2
DMA acknowledge		→		DMACK-
DMA request		←		DMARQ
Interrupt request		←		INTRQ
I/O read		→		DIOR-
I/O ready		←		IORDY
I/O write		→		DIOW-

Passed diagnostics	(see note)	PDIAG-
Reset	→	RESET-
NOTE – See signal descriptions for information on source of these signals		

Signal Descriptions

CS0- (CHIP SELECT 0)

This is the chip select signal from the host used to select the Command Block registers.

CS1 – (CHIP SELECT 1)

This is the chip select signal from the host used to select the Control Block registers.

DA2, DA1, AND DA0 (DEVICE ADDRESS)

This is the 3-bit binary coded address asserted by the host to access a register or data port in the device.

DASP – (Device active, device 1 present)

This is a time-multiplexed signal which indicates that a device is active, or that Device 1 is present. This signal shall be an open collector output and each device shall have a 10 k pull-up resistor.

If the host connects to the DASP- signal for the illumination of an LED or for any other purpose, the host shall ensure that the signal level seen on the ATA interface for DASP- shall maintain V_{OH} and V_{OL} compatibility, given the b_H and b_L requirements of the DASP- device drivers.

DD (15:0) (Device data)

This is an 8- or 16-bit bi-directional data interface between the host and the device. The lower 8 bits are used for 8-bit register transfers.

DIOR- (Device I/O read)

This is the read strobe signal from the host. The falling edge of DIOR- enables data from the device onto the signals, DD (7:0) or DD (15:0). The rising edge of DIOR- latches data at the host and the host shall not act on the data until it is latched.

DIOW- (Device I/O write)

This is the Write strobe signal from the host. This rising edge of DIOW- latches data from the signals, DD (7:0) or DD (15:0), into the device. The device shall not act on the data until it is latched.

DMACK- (DMA acknowledge)

This signal shall be used by the host in response to DMARQ to initiate DMA transfers.

DMARQ (DMA request)

This signal, used for DMA data transfer between host and device, shall be asserted by the device when it is ready to transfer data to or from the host. The direction of data transfer is controlled by DIOR- and DIOW-. This signal is used in a handshake manner with DMACK- i.e., the device shall wait until the host asserts DMACK- before negating DMARQ, and re-asserting DMARQ if there is more data to transfer.

This line shall be released (high impedance state) whenever the device is not selected or is selected and no DMA command is in progress. When enabled by DMA transfer, it shall be driven high and low by the device.

When a DMA operation is enabled, CS0- and CS1- shall not be asserted and transfers shall be 16-bits wide.

INTRQ (Device interrupt)

This signal is used to interrupt the host system. INTRQ is asserted only when the device

has a pending interrupt, the device is selected, and the host has cleared the nIEN bit in the Device Control register. If the nIEN bit is equal to one, or the device is not selected, this output is in a high impedance state, regardless of the presence or absence of pending interrupt.

The pending interrupt condition shall be set by:

- the completion of a command; or
- at the beginning of each data block to be transferred for PIO transfers except for the first data block for FORMAT TRACK, WRITE SECTOR(S), WRITE BUFFER, and WRITE LONG commands.

The pending interrupt condition shall be cleared by:

- assertion of RESET-; or
- the setting of the SRST bit of the Device Control register; or
- the host writing the Command register; or
- The host reading the Status register.

IOCS 16- (Device 16-bit I/O)

Obsolete.

IORDY (I/O channel ready)

This signal is negated to extend the host transfer cycle of any host register access (Read or Write) when the device is not ready to respond to a data transfer request.

If actively asserted, the signal only be enabled during DIOR-/DIOW- cycles to the selected device. If open collector, when IORDY is not negated, it shall be in the high-impedance (undriven) state.

This use of IORDY is required for PIO modes 3 and above and otherwise optional.

PDIAG - (Passed diagnostics)

This signal shall be asserted by Device 1 to indicate to Device 0 that it has completed diagnostics. A 10 k Ω pull-up resistor shall be used on this signal by each device.

The host shall not connect to the PDIAG-signal.

RESET- (Device reset)

This signal from the host system shall be asserted beginning with the application of power and held asserted until at least 25 μ s after voltage levels have stabilized within tolerance during power on and negated thereafter unless some event requires that the device(s) be reset following power on.

ATA devices shall not recognize a signal assertion shorter than 20 ns valid reset signal. Devices may respond to any signal assertion greater than 20 ns, and shall recognize a signal equal to or greater than 25 μ s.

CSEL (Cable select)

The device is configured as either Device 0 or Device 1 depending upon the value of CSEL.

Interface Register Definitions And Descriptions

Device addressing considerations

In traditional controller operation, only the selected device receives commands from the host following selection. In this standard, the register contents go to both devices (and their embedded controllers.) The host discriminates between the two by using the DEV bit in the Device/Head register.

Data is transferred in parallel either to or from host memory to the device's buffer under the direction of commands previously transferred from the host. The device performs all of the operations necessary to properly write data to, or read data from, the media. Data read from the media is stored in the device's buffer pending transfer to the host memory and data is transferred from the host memory to the device's buffer to be written to the media.

The devices using this interface shall be programmed by the host computer to perform commands and return status to the host at command completion. When two devices are daisy-chained on the interface, commands are written in parallel to both devices, and for all except the EXECUTE DEVICE DIAGNOSTICS command, only the selected device executes the command. On an EXECUTE DEVICE DIAGNOSTICS command addressed to Device 0, both devices shall execute the command, and Device 1 shall post its status to Device 0 via PDIAG-.

Devices are selected by the DEV bit in the Device/Head register. When the DEV bit is equal to zero, Device 0 is selected. When the DEV bit is equal to one, Device 1 is selected. When devices are daisy chained, one shall be set as Device 0 and the other as Device 1.

I/O register descriptions

Communication to or from the device is through an I/O Register that routes the input or output data to or from registers addressed by the signals from the host (CS0-, CS1-, DA (2:0), DIOR-, AND DIOW-).

The Command Block Registers are used for sending commands to the device or posting status from the device. The Control Block Registers are used for device control and to post alternate status.

Anytime a command is in progress, that is, from the time the Command register is written until the device has completed the command and posted ending status, the device shall have either BSY or DRQ set to one. If the Command Block registers are read by the host when BSY or DRQ is set to one, the content of all register bits and fields except BSY and DRQ in the Status and Alternate Status registers is indeterminate. If the host writes to any Command Block register when BSY or DRQ is set to one, the results are indeterminate and may result in the command in progress ending with a command abort error.

When performing PIO transfers, BSY and DRQ shall both be cleared to zero within 400 ns of the transfer of the final byte of data. This assertion signals the completion of a PIO data transfer command.

Table 3 lists these registers and the addresses that select them.

Table 3 - I/O port functions and selection address

Addresses					Functions	
CS0-	CS1-	DA2	DA1	DA0	Read (DIOR-)	Write (DIOW-)
N	N	x	x	x	Data bus high impedance	Note used
					Control block registers	
N	A	0	x	x	Data bus high impedance	Note used
N	A	1	0	x	Data bus high impedance	Note used
N	A	1	1	0	Alternate Status	Device Control
N	A	1	1	1	(see note1)	Not used
					Command block registers	
A	N	0	0	0	Data	Data
A	N	0	0	1	Error	Features
A	N	0	1	0	Sector Count	Sector Count
A	N	0	1	1	Sector Number LBA (7:0) (see note 2)	Sector Number LBA (7:0) (see note 2)
A	N	1	0	0	Cylinder Low LBA (15:8) (see note 2)	Cylinder Low LBA (15:8) (see note 2)
A	N	1	0	1	Cylinder High LBA (23:16) (see note 2)	Cylinder High LBA (23:16) (see note 2)
A	N	1	1	0	Device/Head LBA (27:24) (see note 2)	Device/Head LBA (27:24) (see note 2)
A	N	1	1	1	Status	Command
A	A	x	x	x	Invalid address	Invalid address
<p>Key: A = signal asserted, N = signal negated, x = don't care</p> <p>NOTES_</p> <p>1 This register is obsolete. It is recommended that a device not respond to a read of this address. If a device does respond, it shall not drive the DD7 signal to prevent possible conflict with floppy disk implementations.</p> <p>2 Mapping of registers in LBA translation.</p>						

Each register description in the following clauses contain the following format:

ADDRESS – the CS and DA address of the register.

DIRECTION – indicates if the register is read/write, read only, or write only from the host.

ACCESS RESTRICTIONS – indicates when the register may be accessed.

EFFECT – indicates the effect of accessing the register.

FUNCTIONAL DESCRIPTION – describes the function of the register.

FIELD/BIT DESCRIPTION – describes the content of the register.

[Duplicate Data, Error and Feature register]

During word access, the address space occupied by the Data Register interferes with the space occupied by the Error register and Feature register, and reference cannot be made to these registers. Therefore, the PC Card ATA Standard provides an area where the copy of each register does not duplicate in the contiguous I/O mode and memory map mode. The even-numbered address of the data register is provided in the offset "08h", and the odd-numbered address of the data register is located in the offset "09h". The copy of Error/Feature register is provided at the ODh.

Duplicate Data register

D15	D14	D13	D12	D11	D10	D9	D8	D7	D6	D5	D4	D3	D2	D1	D0
Data Word															
Odd Data Byte Only								Even or Even-Odd Data Byte							

Duplicate registers Access

Data register	CE2#	CE#	A0	Offset	Data Bus
Word Data register	0	0	0	0h,8h	D15-D0
Word Data register	0	0	1	1h,9h	D15-D0
Even Byte Data register	1	0	0	0h,8h	D7-D0
Odd Byte Data register	1	0	1	9h	D7-D0
Odd Byte Data register	0	1	x	8h,9h	D15-D8
Error/Feature register	1	0	1	1h,0Dh	D7-D0
Error/Feature register	0	1	x	0h,1h	D15-D8
Error/Feature register	0	0	x	0Ch,0Dh	D15-D8

Initial value of task file register

After resetting and execution of the Execute Device Diagnostic command, the task file register is initialized as follows:

Sector Count register	01h
Sector Number register	01h
Cylinder Lo register	00h
Cylinder High register	00h
Device/Head register	A0h

PIO Data Transfers

Figure 1 defines the relationships between the interface signals for PIO data transfers. Peripherals reporting support for PIO Transfer Mode 3 or 4 shall power up in a PIO Transfer Mode 0, 1, or 2.

For PIO modes 3 and above, the minimum value of t_0 is specified by word 68 in the IDENTIFY DEVICE parameter list.

IORDY shall be supported when PIO Mode 3 or 4 are the current mode of operation.

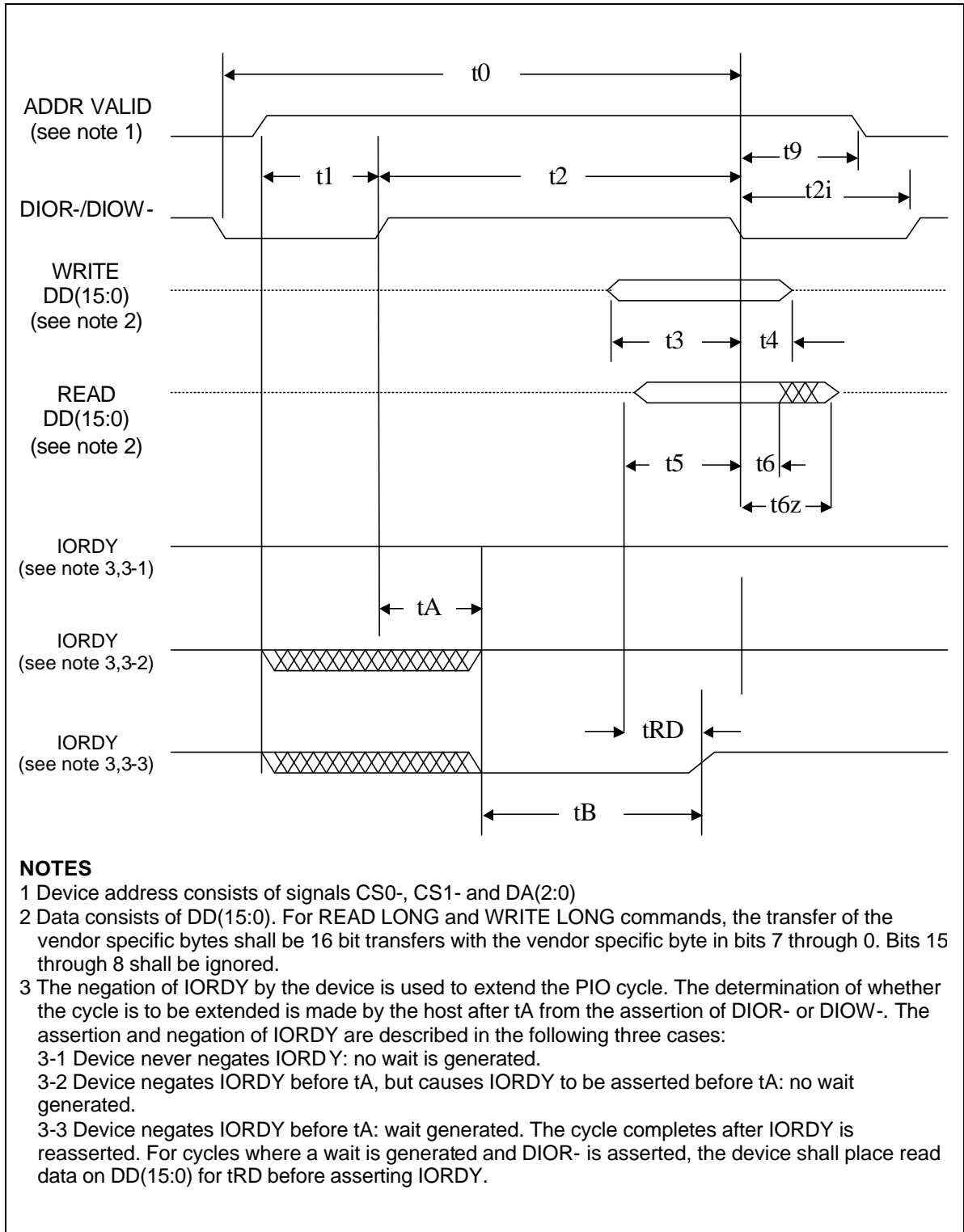

Figure 1 - PIO data transfer to/from

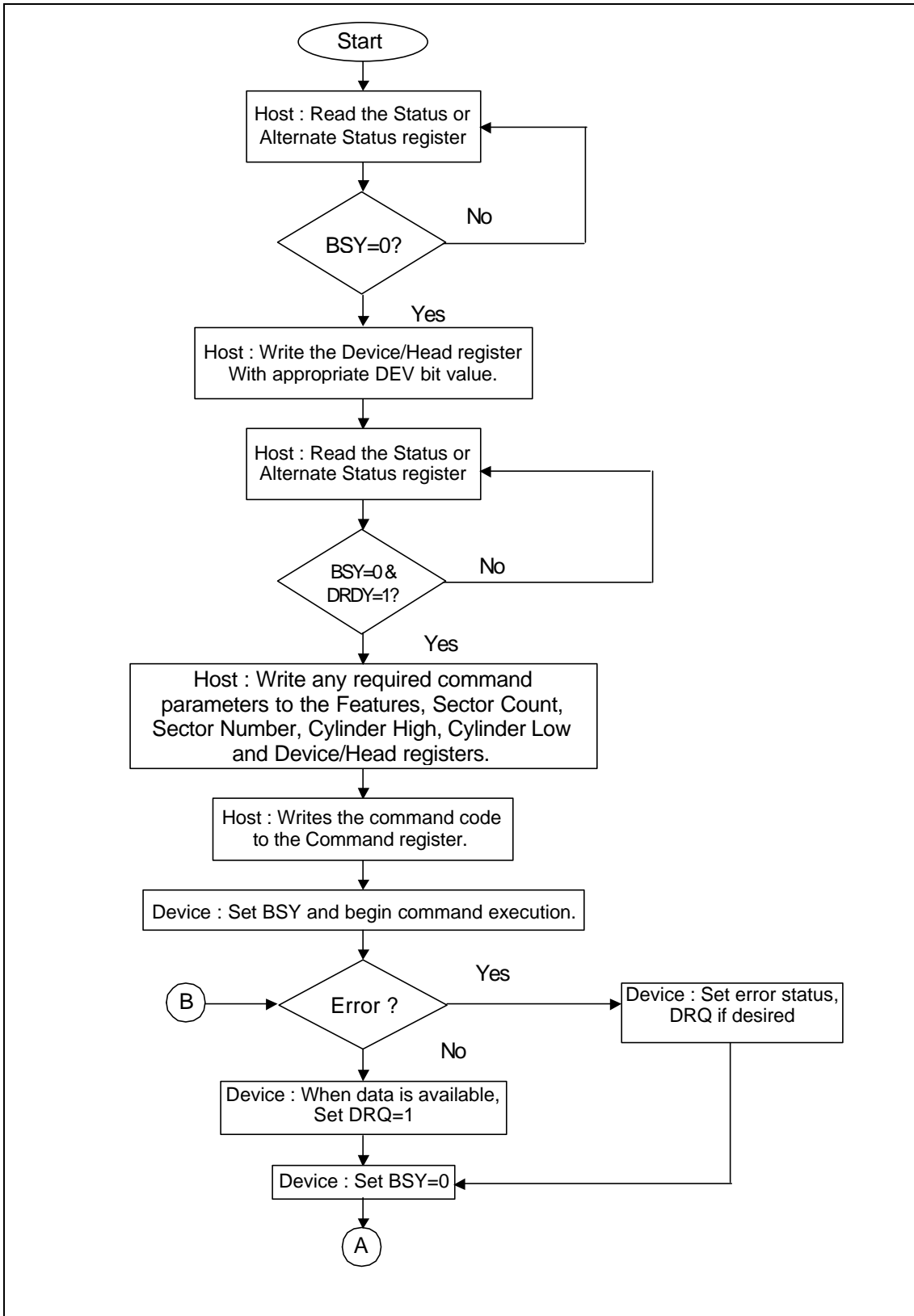

Figure 2 – PIO data transfer in diagram

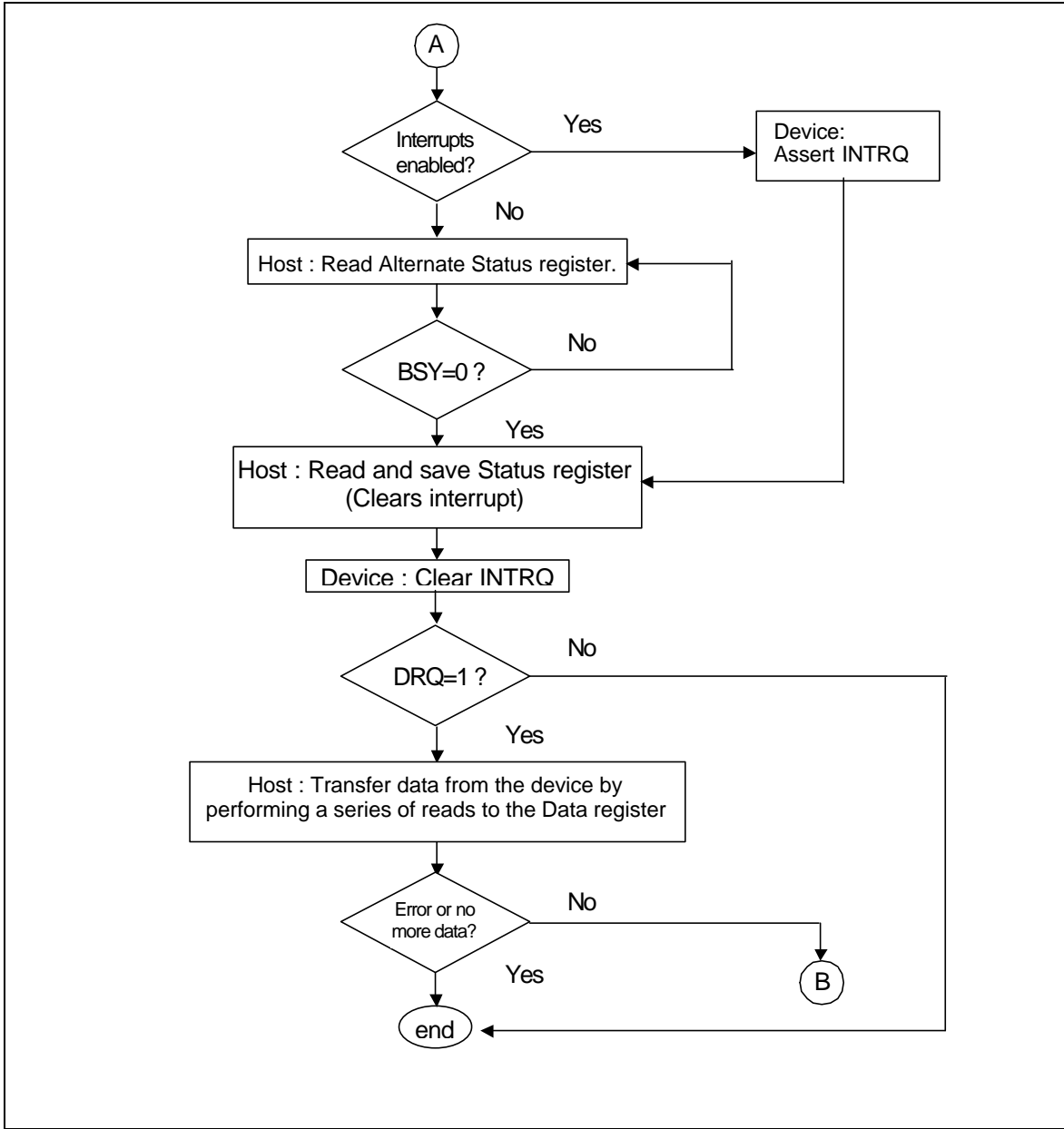

Figure 3 – PIO data transfer in diagram (concluded)

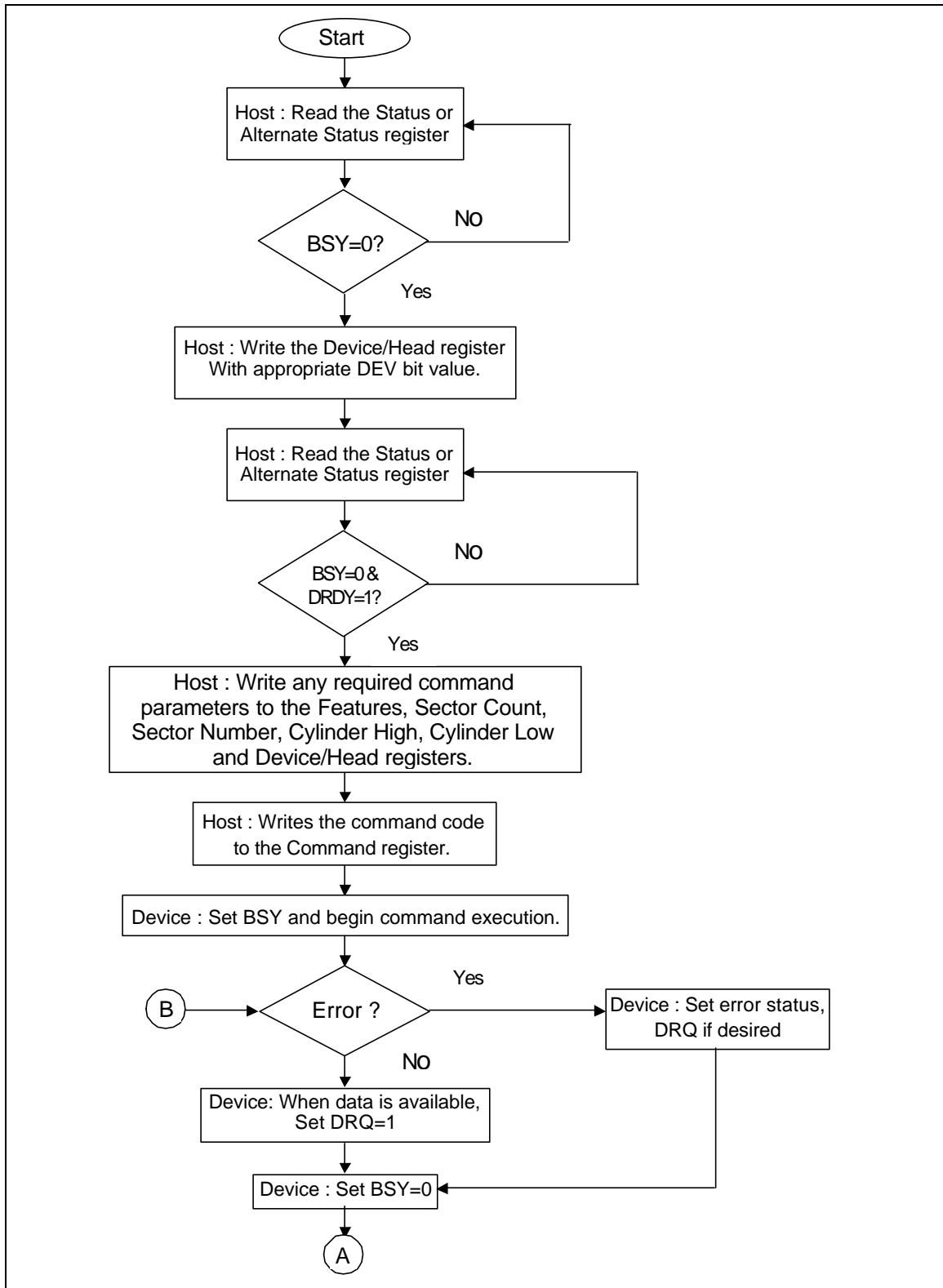

Figure 4 – PIO data transfer out diagram (continued)

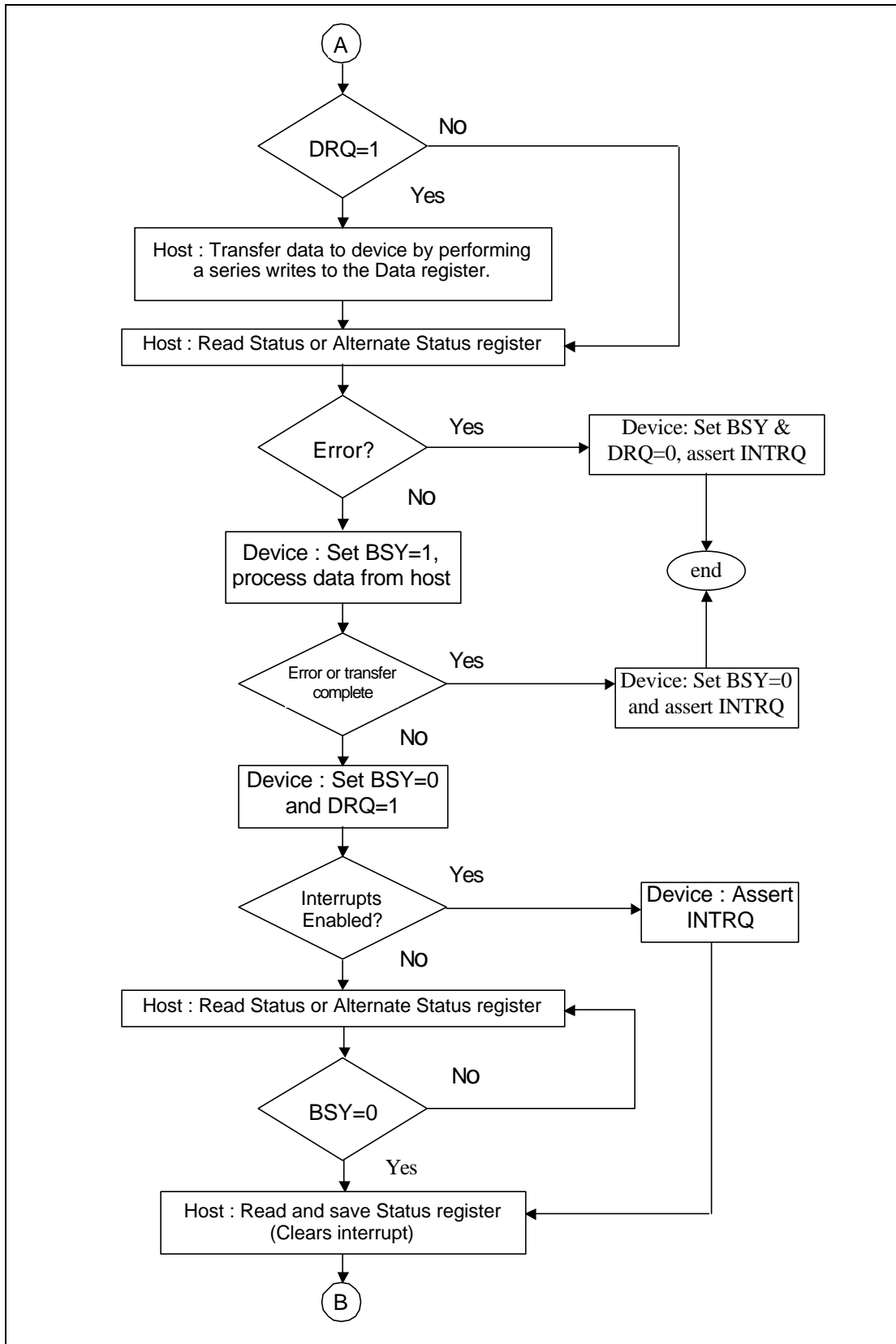
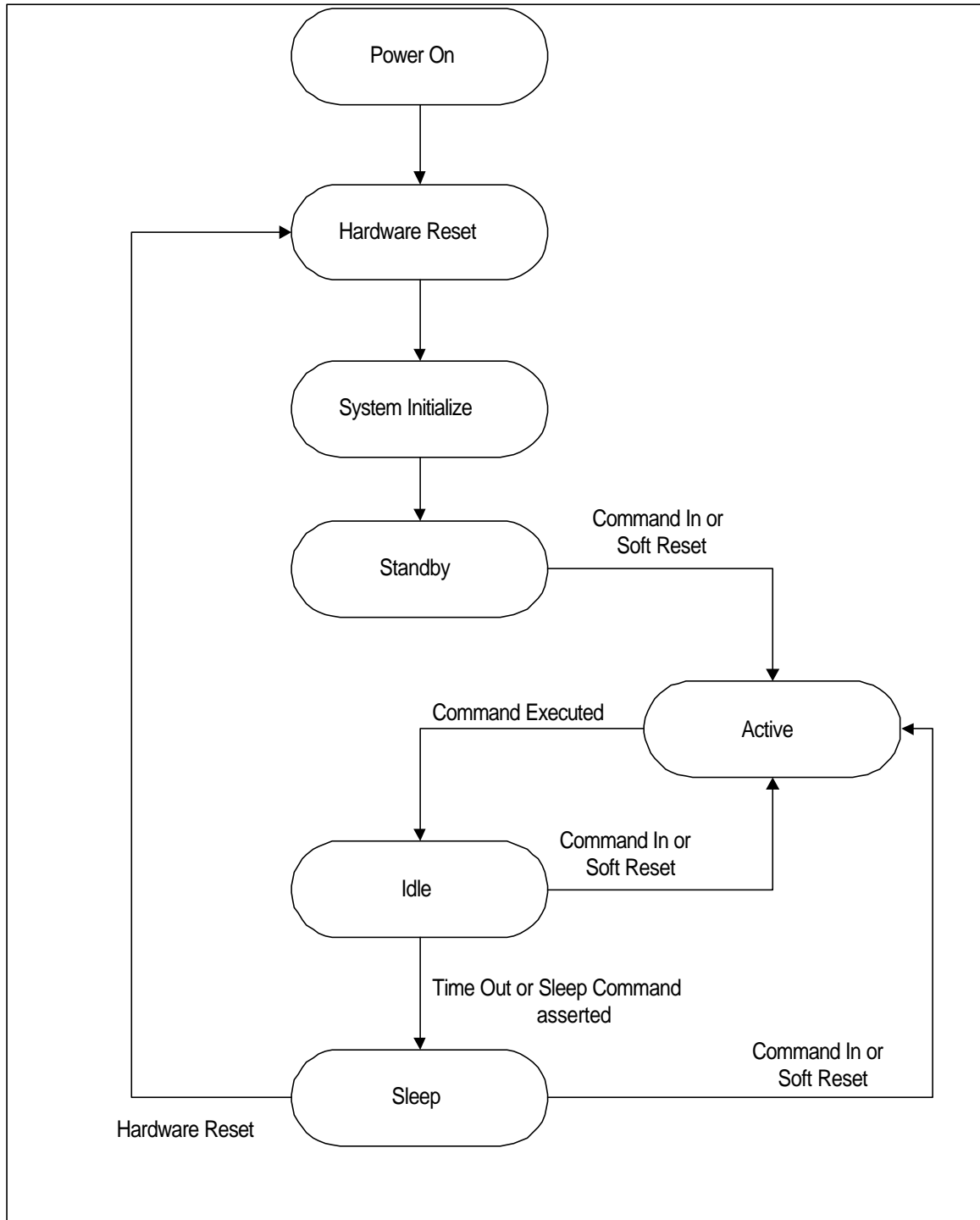

Figure 5 – PIO data transfer out diagram (concluded)

Power Saving Flow:



G. Electrical Specifications

Absolute Maximum Rating

Item	Symbol	Parameter	MIN	MAX	Unit
1	$V_{DD}-V_{SS}$	DC Power Supply	-0.3	+5.5	V
2	V_{IN}	Input Voltage	$V_{SS}-0.3$	$V_{DD}+0.3$	V
3	Ta	Operating Temperature	0	+70	
4	Tst	Storage Temperature	-20	+85	

H. DC Specifications

H.1. DC Characteristics-1 ($T_a=0$ to $+70$, $V_{CC}= 3.3V \pm 10\%$)

Parameter	Symbol	Conditions	MIN	TYP	MAX	Unit
Input Voltage	VIH	--	2.0	--	$V_{CC} +0.3$	V
	VIL	--	-0.3	--	0.8	V
Output Voltage IOL = 4mA (*1)	VOH	IOL = -4mA	$V_{CC} -0.4$	--	--	V
	VOL	IOL = 4mA	--	--	0.45	V
Input leakage current (*2)	ILK	VIH = VDD / VIL = GND	-10	--	10	uA
Sleep current (*3)	ISP	Control signal = $V_{CC} - 0.2$	--	200	--	uA
Sector read current (*4,*3)	ISR(DC)	Control signal = $V_{CC} - 0.2$	--	20	--	mA
	ISR(Peak)		--	40	--	mA
Sector write current (*5,*3)	ISW(DC)	Control signal = $V_{CC} - 0.2$	--	25	--	mA
	ISW(Peak)		--	50	--	mA

H.2. DC Characteristics-1 ($T_a=0$ to $+70$, $V_{CC}= 5.0V \pm 10\%$)

Parameter	Symbol	Conditions	MIN	TYP	MAX	Unit
Input Voltage	VIH	--	2.0	--	$V_{CC} +0.3$	V
	VIL	--	-0.3	--	0.8	V
Output Voltage IOL = 4mA (*1)	VOH	IOL = -4mA	$V_{CC} -0.4$	--	--	V
	VOL	IOL = 4mA	--	--	0.45	V
Input leakage current (*2)	ILK	VIH = VDD / VIL = GND	-10	--	10	uA
Sleep current (*3)	ISP	Control signal = $V_{CC} - 0.2$	--	200	--	uA
Sector read current (*4,*3)	ISR(DC)	Control signal = $V_{CC} - 0.2$	--	40	--	mA
	ISR(Peak)		--	80	--	mA
Sector write current (*5,*3)	ISW(DC)	Control signal = $V_{CC} - 0.2$	--	55	--	mA
	ISW(Peak)		--	110	--	mA

Note : 1.Measured for static state.

2.Except pulled up input/output pin.

3.Power dissipation is reference value on the assembled flash card, including the flash memory.

4.Measured during sector read transfer.

5.Measured during sector write transfer.

Clock Input Timing

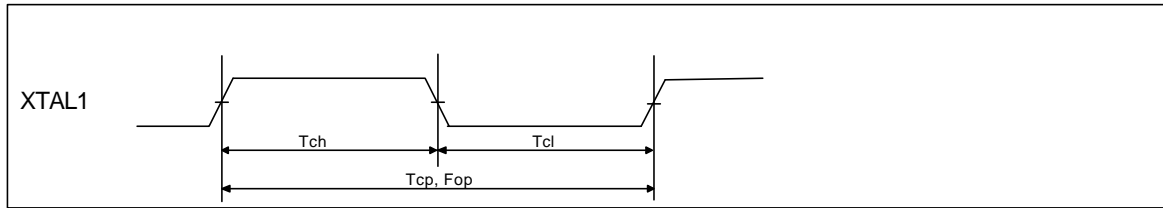

Symbol	Parameter	Min	Max	Unit
Fop	Operating Speed	0	25	MHz
Tcp	Clock Period	40	-	ns
Tch	Clock High	18	-	ns
Tcl	Clock Low	18	-	ns

ATA Command specifications

This table summarizes the ATA command set with the paragraphs. Following shows the support commands

and command codes which are written in command registers.

ATA Command Set

No.	Command set	Code	FR	SC	SN	CY	DR	HD	LBA
2	Execute drive diagnostic	90H	—	—	—	—	Y	—	—
3	Erase sector(s)	C0H	—	Y	Y	Y	Y	Y	Y
4	Format track	50H	—	Y	—	Y	Y	Y	Y
5	Identify Drive	ECH	—	—	—	Y	—	—	—
6	Idle E3H or	97H	—	Y	—	—	Y	—	—
7	Idle immediate	E1H or 95H	—	—	—	Y	—	—	—
8	Initialize drive parameters	91H	—	Y	—	—	Y	Y	—
9	Read buffer	E4H	—	—	—	—	Y	—	—
10	Read multiple	C4H	—	Y	Y	Y	Y	Y	Y
11	Read long sector	22H, 23H	—	—	Y	Y	Y	Y	Y
12	Read sector (s)	20H, 21H	—	Y	Y	Y	Y	Y	Y
13	Read verify sector (s)	40H, 41H	—	Y	Y	Y	Y	Y	Y
14	Recalibrate	1XH	—	—	—	—	Y	—	—
15	Request sense	03H	—	—	—	—	Y	—	—
16	Seek	7XH	—	—	Y	Y	Y	Y	Y
17	Set features	EFH	Y	—	—	—	Y	—	—
18	Set multiple mode	C6H	—	Y	—	—	Y	—	—
19	Set sleep mode	E6H or 99H	—	—	—	—	Y	—	—
20	Stand by	E2H or 96H	—	—	—	—	Y	—	—
21	Stand by immediate	E0H or 94H	—	—	—	—	Y	—	—
22	Translate sector	87H	—	Y	Y	Y	Y	Y	Y
23	Wear level	F5H	—	—	—	—	Y	Y	—
24	Write buffer	E8H	—	—	—	—	Y	—	—
25	Write long sector	32H or 33H	—	—	Y	Y	Y	Y	Y
26	Write multiple	C5H	—	Y	Y	Y	Y	Y	Y
27	Write multiple w/o erase	CDH	—	Y	Y	Y	Y	Y	Y
28	Write sector	30H or 31H	—	Y	Y	Y	Y	Y	Y
29	Write sector(s) w/o erase	38H	—	Y	Y	Y	Y	Y	Y
30	Write verify	3CH	—	Y	Y	Y	Y	Y	Y

.Note: FR: Feature Register

SC: Sector Count register (00H to FFH)

SN: Sector Number register (01H to 20H)

CY: Cylinder Low/High register (to)

DR: Drive bit of Drive/Head register

HD: Head No.(0 to 3) of Drive/Head register

NH: No. of Heads

Y: Set up

- : Not set up

- 1.Check Power Mode (code: E5H or 98H): This command checks the power mode.
- 2.Execute Drive Diagnostic (code: 90H): This command performs the internal diagnostic tests implemented by the Card.
- 3.Erase Sector(s) (code: C0H): This command is used to erase data sectors.
- 4.Format Track (code: 50H): This command writes the desired head and cylinder of the selected drive.
But selected sector data is not exchange. This card expects a sector buffer of data from the host to follow the command with same protocol as the Write Sector Command.
- 5.Identify Drive (code: ECH): This command enables the host to receive parameter information from the Card.

Physical Outline

FDXXX-019PS.XQ6(XXX)

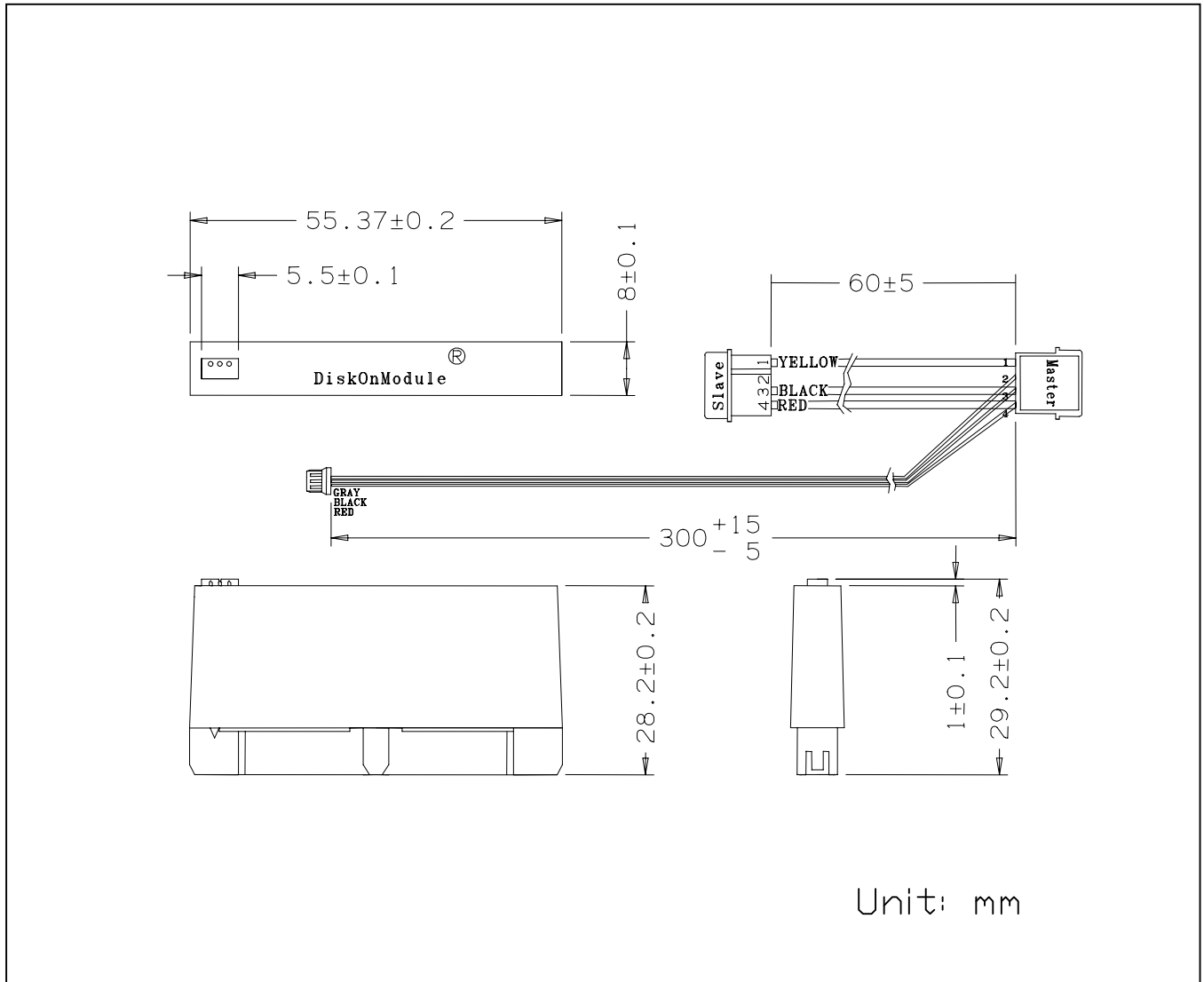

Physical Outline

FDXXX-019PSR.XQ6(XXX)

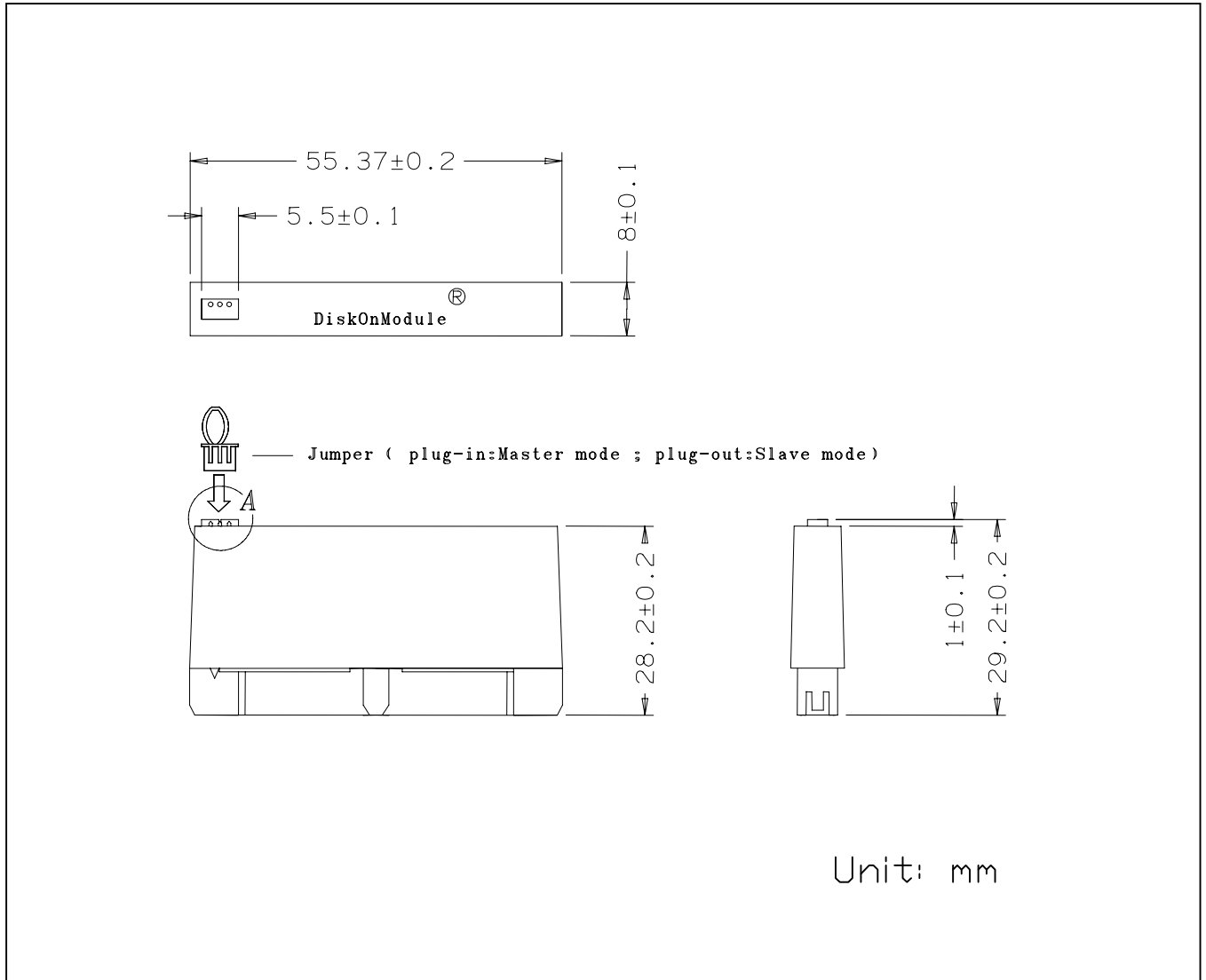

Physical Outline

FDXXX-426PS.XQ6(XXX)

